

# Signature Series

Maximum Resilience Broadcast Audio



## Signature AoIP44

Dante Network Audio Interface

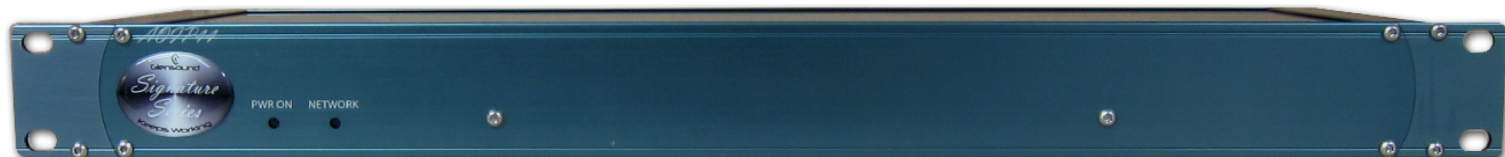

AoIP44 Front



AoIP44 Rear

## FEATURES

**4 x inputs  
4 x outputs  
on analogue XLR**

**Network link  
on Neutrik  
EtherCON**

**Routing control  
via free  
Dante Controller**

**Power via  
100-240VAC  
or  $\pm 12$ VDC**

The AoIP44 is an economical subrack designed to interface balanced analogue audio circuits to and from a network audio system featuring Dante. It provides 4 audio inputs to the network and also 4 audio outputs from the network on balanced 3 pin XLRs.

The AoIP44 can be used as a simple low cost audio I/O break out unit on a large Dante audio network where it can be integrated extremely easily using the Dante Controller and is fully compatible with any manufacturers Dante equipment.

The AoIP44 can also be used in very simple audio over IP scenarios where 4 bi-directional audio circuits are needed to be distributed across a buildings network infrastructure, in which

case 2 x AoIP44 units can be used connected together across the network. The AoIP44 is equally suited for high integrity broadcast purposes, intercom, just simple paging facilities or simple distribution of audio.

Being part of our Signature Range, the AoIP44 comes as standard with removeable rack ears (to allow front or rear mounting in 19" racks), mounting holes to allow under desk mounting (the holes are equally suited for screwing the unit into odd places!) and an optional external DC power supply for applications requiring redundant power supplies. It is housed in an all anodised aluminium chassis.



**Glensound**  
Keeps Working

**Dante™**



### Signature AoIP44

4 x 4 Network Audio Interface

#### EXAMPLE APPLICATION

### Interface To Existing Dante Network

#### Commentary Unit Connection To An Existing Dante Network

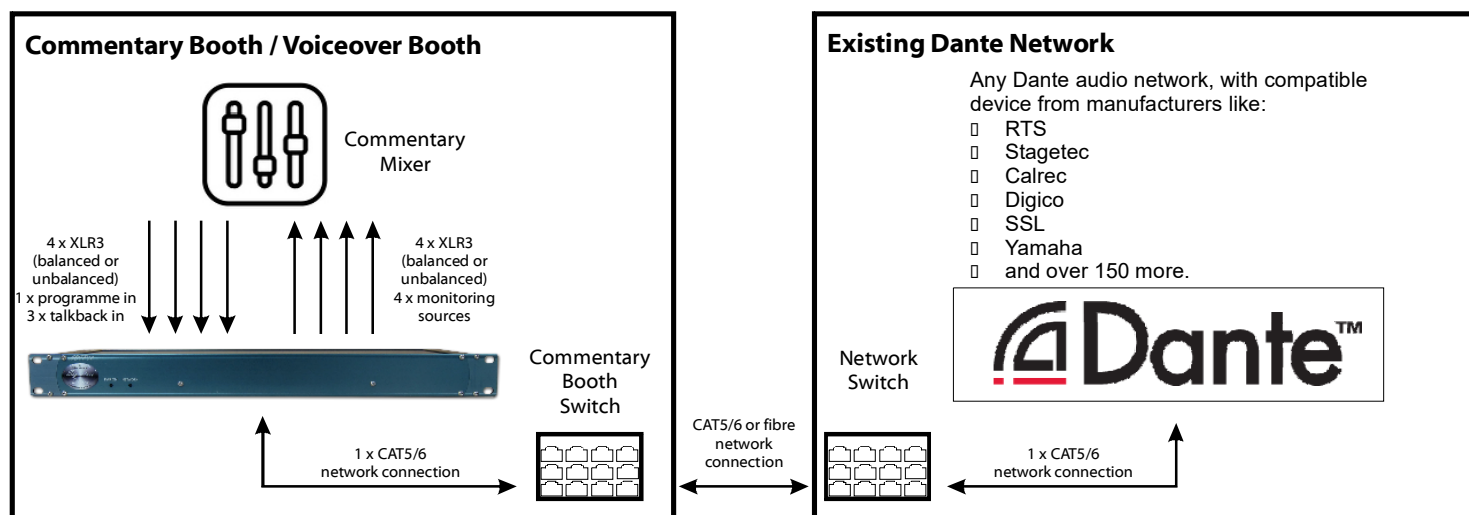

There are over 150 manufacturers that design Dante compatible equipment. In this example, the broadcaster has an established Dante network. This is most likely to be an audio console, or an intercom system.

The broadcaster needs to expand the network by adding an existing commentary booth / voice over position. Using the AoIP44, the commentary position can be added to the existing Dante network very cost effectively.

The AoIP44 is located in the commentary booth, and connected into the broadcast network via a single CAT5/6 cable.

The Glensound GS-CU001B is the most widely used commentary unit by broadcasters. It provides a programme mix output (direct outputs also available), and has 3 talkback outputs. These connect to the inputs of the AoIP44 via XLR connections.

The AoIP44 outputs connect to the headphone monitoring inputs on the GS-CU001B via XLR. This allows the commentators to hear 4 channels. These are typically the programme audio, and talkback returns.

The audio routing can be configured via the Dante Controller software. Simply run Dante Controller on any PC connected to the network. All available sources and destinations will be shown on the AoIP44, and all other Dante compatible devices on the network. Click the check boxes to route the audio in the desired directions, and the system is now ready to be used.

Audio routing only needs to be configured by Dante Controller on the first time the AoIP44 is connected to the network as all routes are stored locally on the device.





### Signature AoIP44

4 x 4 Network Audio Interface

#### EXAMPLE APPLICATION

### Interface To News/Voice Over Studio

Programme Send With Stereo Return Monitoring

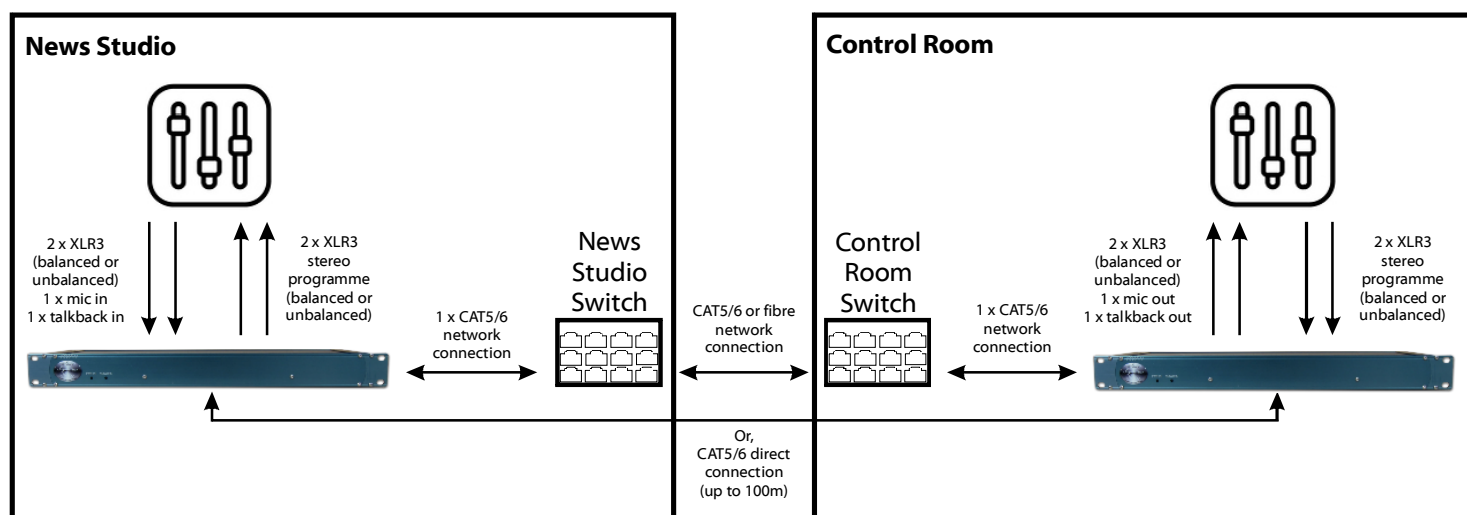

A small voice over studio is used for production of voice recording and by the newsreaders. This is a separate studio to the main studios, and separate from the control room.

As there are only a few channels to transmit between the locations the AoIP44 is a cost effective option for connecting the bi-directional audio.

The mixer in the voice over studio only has 2 outputs: the direct output of the microphone, and a separate talkback channel. These connect to the local AoIP44 via XLR. There is a local network switch in the voice over studio and this connects via a spare port to the AoIP44 via CAT5/6, so that it is now recognised on the local network.

A second AoIP44 connects to the local network switch in the control room via a CAT5/6 connection. Two of the audio outputs from the AoIP44 are connected to the control room mixer via XLR.

We will configure this as the 2 channels of audio coming from the voice over studio. The stereo programme output from the control room mixer is connected to two of the AoIP44 inputs via XLR. All of the physical audio connections have now been made.

As both AoIP44s are connected on the network, the audio routing can be configured via the Dante Controller software. Simply run Dante Controller on any PC connected to the network and both AoIP44s will be displayed showing available sources and destinations. Click the check boxes to route the audio in the desired directions, and the system is now ready to be used.

Over shorter distances, network switches are not even required and 2 x AoIP44s can connect directly. Audio routing still needs to be configured by Dante Controller on the units when they are connected to a network, but this is only required once to set the required routing.





### Signature AoIP44

Dante Network Audio Interface

## SPECIFICATION

### AUDIO

**Frequency Response**  $\leq 0.25\text{dB}$ 

Flat until 22k

**Maximum Input Before Clip**

+18dBu

**Maximum Output Level**

+18dBu

**Input Impedance**

>20k Ohm

**Output Impedance**

50 Ohms

**Distortion**

0.013% THD @ 100Hz, 1kHz & 10kHz

Reference to +8dBu output

**Noise Residual**

-94.6dBu

**THD+N Relative (1k +8dBu)**

0.00134%

**Dynamic Range**

112.6dBs

**Crosstalk (0dBu input to output 1k tone)**

-94.7dBu

**Output Type**

Electronically balanced (can be wired unbalanced) on Neutrik 3 pin XLR plug

**Input Type**

Electronically balanced (can be wired Unbalanced) on Neutrik 3 pin XLR socket

### NETWORK AUDIO

**Compatible Audio Networks**

Dante uncompressed, low latency audio.

For full details visit [www.audinate.com](http://www.audinate.com)

**Network Connection**

Neutrik RJ45 EtherCON

**Dante Network Sample Rate**

44.1k, 48k, 88.2k, 96k

### POWER

**Mains Input**

Filtered IEC, 100 to 240VAC

47 - 63Hz

**AC Consumption**

4.3 Watts @ 230VAC

**DC Input**

4 Pin Neutrik XLR. +12v 240mA, -12v N/A

**Internal Mains Fuse**

20mm 1A Anti Surge

### PHYSICAL

**Size**

445 x 123 x 44mm (LxDxH) no rack ears

482mm length (19" 1RU) with rack ears

**Weight**

1.2kg

**Mechanics**

All aluminium construction, anodized and laser etched

**Shipping Carton**

Rugged export quality cardboard carton

610 x 420 x 130mm LxDxH

**Shipping Weight**

2.7kg

E & OE



# Signature Series

Maximum Resilience Broadcast Audio



## Signature AoIP44 Network Audio Interface

### AUDIO BLOCK DIAGRAM

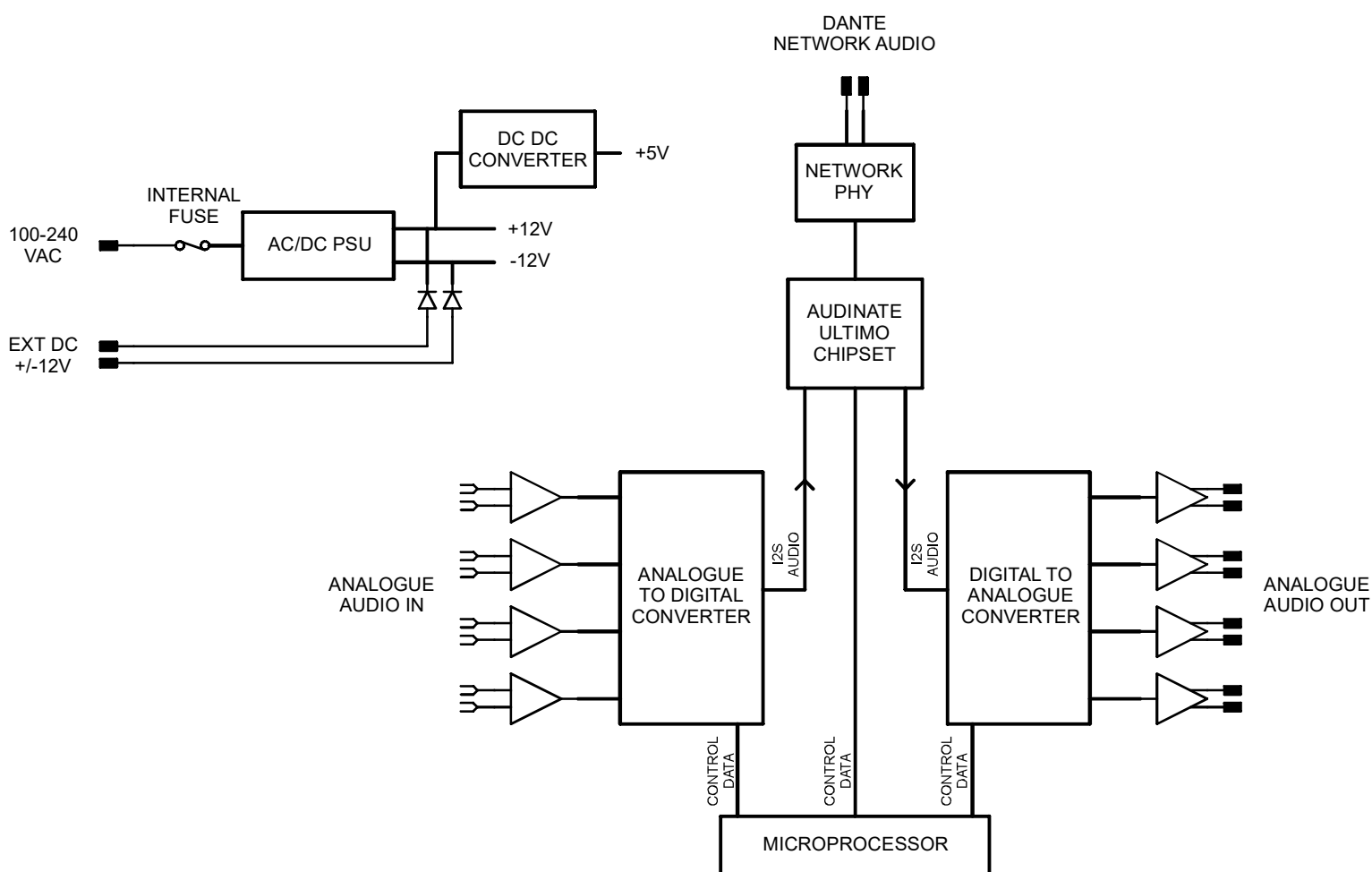

# Signature Series

## Maximum Resilience Broadcast Audio



### Signature Series Standard Features

#### STANDARD FEATURES

##### 19" Rack Mount Ears



A Signature unit can rack mount in a 1U 19" rack, regardless of the size of the unit. Rack ears are included as standard with every unit.

##### Front Or Rear Mounting



A Signature unit can be rack mounted via the front panel or if it is more convenient, via the rear panel by simply swapping the rack ears over.

##### Side Wings For Flat Surface Fixing



A Signature unit has side wings with mounting holes at the top and bottom, allowing flush fixing from above **OR** underneath.

##### Neutral Colour Scheme To Compliment Equipment Areas



##### Rack Screws Included



##### Modern Design



##### Internal Switch Mode AC Power Supply



A Signature unit has an internal switch mode AC power supply, allowing worldwide power connections from 100-240v via an IEC socket.

##### 12V DC Power Connection



All Signature units (except PS1) have a 4 pin XLR  $\pm 12V$  DC socket for connection to the PS1 Power Station. This can act as the primary or backup power source.

##### Quick Find Manual



A Signature unit has a QR code attached. This can be scanned to simply and quickly locate the manual and technical information.

#### CONTACT

**Glensound**  
6 Brooks Place, Maidstone  
Kent, UK, ME14 1HE  
Tel: +44 (0)1622 753 662  
Web: [www.glensound.co.uk](http://www.glensound.co.uk)  
Email: [sales@glensound.co.uk](mailto:sales@glensound.co.uk)

